

MANUAL DE MONTAJE
 NOTICE DE MONTAGE
 ASSEMBLY MANUAL
 MANUALE PER IL MONTAGGIO
 MONTAGEANLEITUNG
 MANUAL DE MONTAGEM
 INSTRUKCJE MONTAZOWE

STUO

V. 01 - 10/18

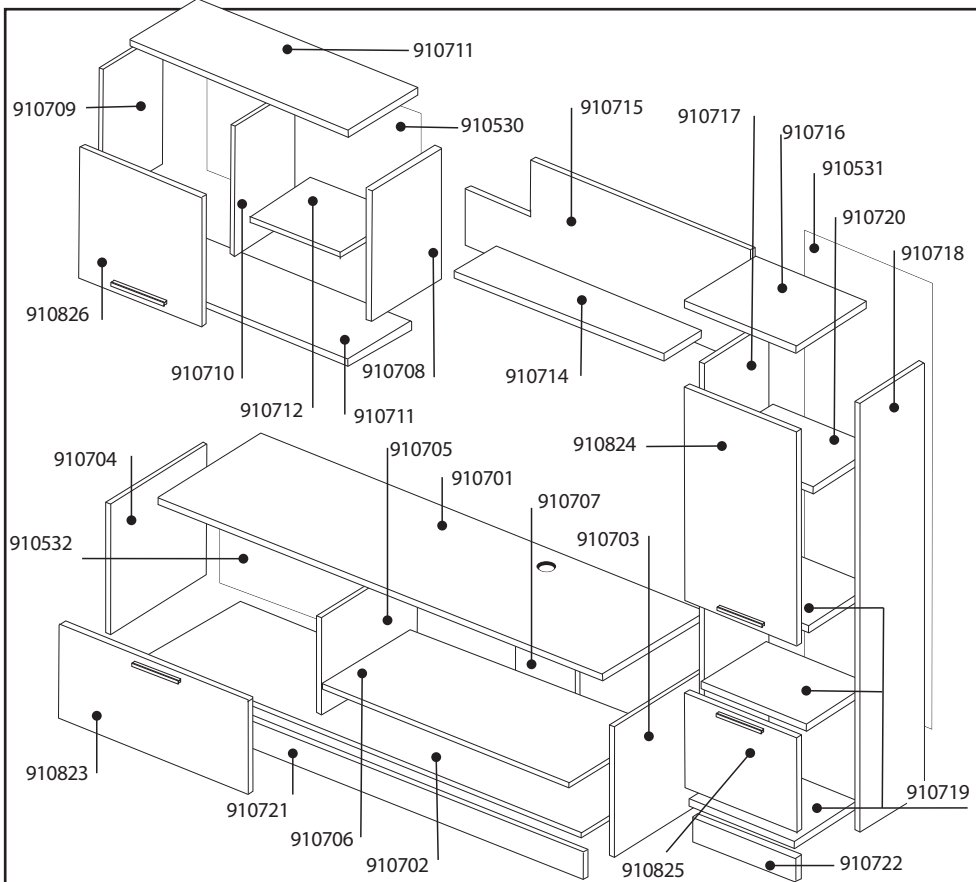
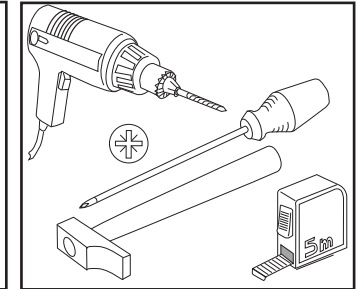
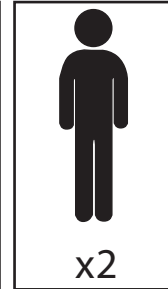
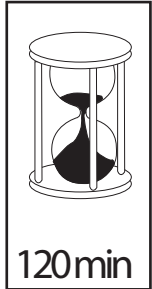
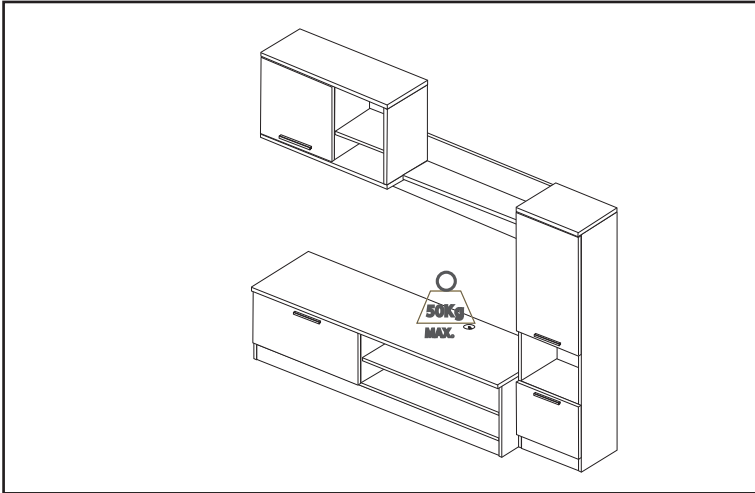

ANTES DE EMPEZAR
 CONSULTE LOS CONSEJOS
 PARA EL MONTAJE.

AVANT DE COMMENCER
 CONSULTEZ LES
 INSTRUCTIONS DE MONTAGE.

BEFORE STARTING REFER TO
 THE ASSEMBY ADVICE.

PRIMA DI INIZIARE LEGGERE
 I CONIGLI PER IL MONTAGGIO.

VOR DEM BEGINN EMPFIEHLT
 ES SICH AUFMERKSAM DIE
 HINWEISE ZUR MONTAGE ZU
 LESEN.

ANTES DE COMEÇAR
 CONSULTE OS CONSÉLHOS
 PARA A MONTAGEM .

ZANIM PRZYSTĄPIMY DO
 MONTAŻU , PROSIMY
 ZAOPZNAC SIĘ Z
 NASTĘPUJĄCYMI
 WSKAZÓWKAMI.

x8 PE845	x8 EX16	x6 TE17 B	x12 CL830	x4 PE5	x90 P1010	x45 TA550	x45 TA3B	x1 LLA3	x10 TSR	x4 AFCB110	x32 TP3515	x8 EA3030	x4 TEMB18C	x4 TAPALU
x8 BA26E	x8 B26R	x16 TP3515	x4 ECT10	x26 TP3515	x14 TP3530	x2 GRTG	x2 CGB100	x2 ELCG	x2 EPMC	x1 COLA	x1 PC60A	x1 CT715		

Español (es) - Información importante sobre el montaje de los muebles en pared, leer detenidamente y guardar esta información para consultarla en el futuro.

ADVERTENCIA

Una vez montado según las instrucciones de montaje, el mueble está listo para fijarlo a la pared. Pueden producirse lesiones graves o fatales si vuelca un mueble. Para evitar que vuelque este mueble, debe fijarse permanentemente a la pared. Trasman Penedès no se hace responsable de daños personales ocasionados por un montaje de pared incorrecto.

No están incluidos los tornillos para montaje en pared. Póngase en contacto con su ferretero local que le asesorará en la elección del sistema de tornillos correcto para el tipo de material de pared, dado que los diversos materiales de pared requieren diferentes tipos de herrajes de fijación.

Français (fr) - Informations importantes concernant le montage mural de notre mobilier, a lire attentivement, conserver ces informations pour un usage ultérieur.

AVERTISSEMENT

Après avoir assemblé votre meuble en suivant le mode d'emploi, vous pouvez le monter au mur. Risque de blessure grave en cas de chute du meuble. Pour éviter que le meuble ne bascule, il faut le fixer au mur de façon permanente. Trasman Penedès décline toute responsabilité en cas de blessures ou de dommages matériels dus à un montage mural incorrect.

Aucune vis n'est fournie pour le montage mural. Contactez votre quincaillier local pour sélectionner une visserie adaptée au matériau de construction de votre mur, car leur choix dépend du matériau du mur sur lequel est fixé le meuble.

English (en) - Important information concerning wall mounting of furniture, read carefully and keep this information for further reference.

WARNING

After you have assembled this product according to the assembly instructions, it can be mounted on a wall. Serious or fatal crushing injuries can occur from furniture tip-over. To prevent this furniture from tipping over it must be permanently fixed to the wall. Trasman Penedès cannot be held liable for personal or material injury as a result of incorrect mounting.

Screws for wall mounting are not included. Please contact your local specialist to ensure the correct choice of screws in relation to the wall material since different wall materials require different types of fixing devices. Use fixing devices suitable for the walls in your home.

Italiano (it) - Informazioni importanti per il fissaggio alla parete dell'armadietto per le scarpe, leggi attentamente e conserva queste informazioni per ulteriori consultazioni.

AVVERTENZA

Durante il montaggio questo armadietto per le scarpe andrà fissato alla parete. Se il mobile si ribalta può causare lesioni da compressione serie o fatali. Per prevenire il rischio che il mobile ribalti permanentemente alla parete. Trasman Penedès non potrà essere ritenuto responsabile dei danni a persone o cose dovuti ad un montaggio non corretto.

Le viti per il fissaggio a parete non sono in dotazione. Rivolgersi al locale negoziante specializzato per essere sicuri che le viti corrispondano al materiale della parete perché pareti di materiali diversi richiedono tipi diversi di accessori di fissaggio.

Deutsch (de) - Wichtige Information betr. Wandbefestigung des Schuhschranks, sorgfältig lesen, diese Information aufbewahren

ACHTUNG

Beim Zusammenbau dieses Schrankes müssen Sie das Möbelstück an der Wand befestigen. Wenn Möbelstücke umkippen, können ernste oder lebensgefährliche Verletzungen durch Einklemmen die Folge sein. Um zu verhindern, dass das Möbelstück umkippt, muss es fest an der Wand verankert werden. Trasman Penedès haftet nicht für Personen- oder Sachschäden, die auf eine unsachgemäße Wandmontage zurückgeführt werden können.

Schrauben für die Wandmontage gehören nicht zum Lieferumfang. Für die korrekte Wahl eines für das jeweilige Wandmaterial geeigneten Schraubensystems wenden Sie sich bitte an den Fachhandel vor Ort, da dieses von der jeweiligen Wandbeschaffenheit abhängig ist.

Português (pt) - Informação importante relativa a montagem na parede do móvel, ler estas instruções cuidadosamente, guardar como referência.

IMPORTANTE

Depois de ter montado o móvel de acordo com as instruções de montagem, pode fixá-lo à parede. As quedas de móveis podem originar esmagamento ou morte. Estes móveis devem ser fixados à parede para evitar possíveis quedas. Trasman Penedès não se responsabiliza por ferimentos pessoais ou danos materiais ou danos como resultado da montagem incorrecta.

Os parafusos necessários para fixar o móvel à parede não estão incluídos. Por favor, contacte o seu especialista local para garantir a escolha correcta de parafusos em relação ao material, os diferentes tipos de parede requerem diferentes tipos de ferragens.

ESPAÑOL

CONSEJOS PARA EL MONTAJE:

- 1-ESTUDIE ATENTAMENTE EL MANUAL DE MONTAJE.
- 2-LOCALICE LAS PIEZAS QUE CONSTITUYEN SU MUEBLE.
- 3-REUNA Y CONTROLE LOS HERRAJES SUMINISTRADOS.
- 4-EQUIPESE CON LAS HERRAMIENTAS NECESARIAS.
- 5-PREPARE UNA ZONA DE MONTAJE.

CONSEJOS PARA EL MANTENIMIENTO:

- 1-QUITAR EL POLVO CUIDADOSAMENTE.
- 2-HUMEDECER UN PAÑO SUAVE Y LIMPIO CON AGUA LIGERAMENTE ENJABONADA.

NO FUERCE NUNCA EN LAS UNIONES APRIETE LOS TORNILLOS DESPUES DE CIERTO TIEMPO DE UTILIZACION. CONSERVE SU MANUAL DE MONTAJE.SI FALTARA UNA PIEZA SERIA LA MANERA MAS FACIL DE COMUNICARLO A LA TIENDA.

NO USE NUNCA PRODUCTOS ABRASIVOS TALES COMO: LANA DE ACERO , LIJAS,DISOLVENTES,ETC. NO MOJAR NI SOMETER A GRANDES HUMEDADES AL MUEBLE.



FRANCAIS

INSTRUCTIONS DE MONTAGE:

- 1-LISEZ ATTENTIVEMENT LA NOTICE DE MONTAGE.
- 2-REPEREZ LES PIECES QUI COMPOSENT VOTRE MEUBLE.
- 3-REGROUPEZ ET VERIFIEZ LES FERRURES FOURNIES.
- 4-DOTEZ-VOUS DES OUTILS NECESSAIRES.
- 5-PREPAREZ UN ESPACE DE MONTAGE.

CONSEILS D'ENTRETIEN:

- 1-ENLEVEZ SOIGNEUSEMENT LA POUSSIERE.
- 2-HUMIDIFIEZ UN CHIFFON DOUX ET PROPRE AVEC DE L'EAU LEGEREMENT SAVONNEUSE.

NE FORCEZ JAMAIS LES RACCORDS. RESSERREZ LES VIS APRES UN CERTAIN TEMPS D'UTILISATION. CONSERVEZ LA NOTICE DE MONTAGE.EN CAS DE PIECE MANQUANTE , CE SERA LE MEILLEUR MOYEN D'EN INFORMER LE MAGASIN.

N'UTILISEZ JAMAIS DES PRODUITS ABRASIFS COMME DE LA LAINE D'ACIER, DU PAPIER DE VERRE, DES SOLVANTS, ETC. NE MOUILLEZ PAS LE MEUBLE ET EVITEZ TOUTE ESPOSITION A UNE HUMIDITE IMPORTANTE.

DEUTSCH

HINWEISE ZUR MONTAGE:

- 1- LESEN SIE AUFMERKSAM DIE MONTAGEANLEITUNG DURCH.
- 2- LOKALISIEREN SIE DIE ZUM MÖBEL GEHÖRENDE TEILE.
- 3- KONTROLLIEREN SIE DIE MITGELIEFERTEN WERKZEUGE.
- 4- RÜSTEN SIE SICH MIT DEN ZUSÄTZLICH BENÖTIGTEN WERKZEUGEN AUS.
- 5- BEREITEN SIE EINEN PLATZ FÜR DIE MONTAGE VOR.

HINWEISE ZUR PFLEGE:

- 1- ENTFERNEN SIE UMSICHTIG DEN ANGESAMMELTEN STAUB.
- 2- VERWENDEN SIE EIN WEICHES UND SAUBERES TUCH UND SCHWACHE SEIFENLAUGE.

FORCIEREN SIE NIEMALS DIE VERBINDUNGEN. ZIEHEN SIE DIE SCHRAUBEN NACH EINER BESTIMMTEN NUTZUNGSZEIT NACH. BEWAHREN SIE DIE MONTAGEANLEITUNG AUF. SOLLTE EIN TEIL FEHLEN IST SIE VON GROSSER WICHTIGKEIT BEI DER NACHBESTELLUNG IM LADEN.

VERWENDEN SIE NIEMALS SCHEUERENDE PRODUKTE WIE STAHLWOLLE, SCHMIRGELPAPIER, LÖSUNGSMITTEL UND DERGL. WASSER UND HOHE FEUCHTIGKEIT SIND SCHÄDLICH FÜR DAS MÖBEL

ITALIANO

CONSIGLI PER IL MONTAGGIO:

- 1- STUDIARE ATTENTAMENTE IL MANUALE DI MONTAGGIO.
- 2- INDIVIDUARE LE PARTI CHE COSTITUISCONO IL MOBILE.
- 3- RACCOGLIERE E CONTROLLARE GLI ATTREZZI IN DOTAZIONE.
- 4- PROCURARSI GLI ATTREZZI NECESSARI.
- 5- PREPARARE UNA ZONA PER IL MONTAGGIO.

CONSIGLI PER LA MANUTENZIONE:

- 1- SPOLVERARE ACCURATAMENTE.
- 2- INUMIDIRE UN PANNINO MORBIDO E PULITO CON ACQUA E POCO DETERGENTE.

NON FORZARE MAI LE GIUNTURE. STRINGERE NUOVAMENTE LE VITI DOPO UN CERTO PERIODO D'USO. CONSERVARE IL MANUALE DI MONTAGGIO: SE MANCASSE UN PEZZO SAREBBE COSÌ PIÙ FACILE COMUNICARLO AL RIVENDITORE.

NON USARE MAI PRODOTTI ABRASIVI COME: SPUGNE ABRASIVE, CARTA VETRATA, SOLVENTI, ECC. NON BAGNARE NE' SOTTOPORRE IL MOBILE A FORTE UMIDITÀ.

POTUGUES

CONSELHO PARA A MONTAGEM :

- 1 - ESTUDE ATENTAMENTE O MANUAL DE MONTAGEM.
- 2 - LOCALIZE AS PEÇAS QUE CONSTITUEM O SEU MÓVEL.
- 3 - REUNA E CONTROLE AS FERRAGENS FORNECIDAS.
- 4 - EQUIPE-SE COM AS FERRAMENTAS NECESSÁRIAS.
- 5 - PREPARE UMA ZONA DE MONTAGEM.

CONSELHOS PARA A MANUTENÇÃO :

- 1- RETIRAR A POEIRA COM CUIDADO.
- 2 - HUMEDECER UM PANO SUAVE E LIMPO COM ÁGUA LIGEIRAMENTE ENSABOADA.

NUNCA FORCE AS UNIÕES. APORTE OS PARAFUSOS DEPOIS DE DETERMINADO TEMPO DE UTILIZAÇÃO. CONSERVE O SEU MANUAL DE MONTAGEM, SE FALTAR UMA PEÇA SERIA A MANEIRA MAIS FÁCIL DE A COMUNICAR À LOJA.

NUNCA USE PRODUTOS ABRASIVOS TAIS COMO : LÃ DE AÇO, LIXAS, DISSOLVENTES, ETC.. NÃO MOLAR NEM SUBMETTER A GRANDES HUMIDADES, O MÓVEL.

POLSKU

WSKAZÓWKI ODNOŚNIE MONTAŻU:

1. PRZECZYTAĆ UWAGNIE NINIEJSZE ZALECENIA.
2. ZLOKALIZOWAĆ CZĘŚCI SKŁADOWE MEBLA.
3. ZEBRAC WSZYSTKIE ELEMENTY ŁACZĄCE.
4. ZAOPATRYĆ SIĘ W NIEZBEDNE NARZĘDZIA.
5. PRZYGOTOWAĆ ODPOWIEDNIE MIEJSCE NA MONTAŻ.

WSKAZÓWKI ODNOŚNIE KONSERWACJI:

1. ODKURZAĆ OSTROŻNIE.
2. W TYM CELU ZWILŻYĆ CZYSTĄ MIEKKĄ SZMATKĘ W SŁABYM ROZTWORZE WODY Z MYDŁEM.

NIE DOCISKAC NA SIŁE ELEMENTÓW ŁACZĄCYCH. DOKRECIĆ ŚRUBY PO UPLYWIE PEWNEGO CZASU. ZACHOWAĆ INSTRUKCJE MONTAŻOWE; W RAZIE BRAKU JAKIEJS CZĘŚCI, ULATWIA ONE KONTAKT ZE SPRZEDAWCĄ.

NIE NALEŻY NIGDY UŻYWAĆ ŚRODKÓW SZORUJĄCYCH, TAKICH JAK WELNA STALOWA, PAPIER SCIERNY, ROZPUSZCZALNIKI I.TP. NIE MOCZYĆ ANI NIE PODDAWAĆ MEBLA DZIAŁANIU DUŻEJ WILGOTNOŚCI.

ENGLISH

ASSEMBLY ADVICE:

- 1- STUDY THE ASSEMBLY MANUAL CAREFULLY.
- 2- LOCATE THE PARTS THAT COMPRISE YOUR FURNITURE ITEM.
- 3- ORGANISE AND CHECK THE FITTINGS SUPPLIED.
- 4- HAVE THE NECESSARY TOOLS TO HAND.
- 5- PREPARE AN ASSEMBLY AREA.

MAINTENANCE ADVICE:

- 1- REMOVE DUST CAREFULLY.
- 2- MOISTEN A SOFT, CLEAN CLOTH WITH SLIGHTLY SOAPY WATER.

DO NOT FORCE ANY OF THE JOINTS. TIGHTEN THE SCREWS AFTER HAVING USED THE FURNITURE FOR SOME TIME. KEEP YOUR ASSEMBLY MANUAL. IF ANY PART IS MISSING, IT WILL HELP YOU TO LET THE SHOP KNOW.

NEVER USE ABRASIVE PRODUCTS SUCH AS STEEL WOOL, SANDPAPER, ETC. DO NOT WET THE FURNITURE OR KEEP IT IN A VERY DAMP PLACE.

1

cm 0 1 2

TP3515  x10

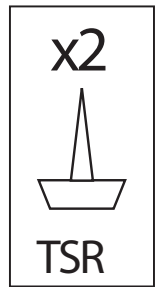
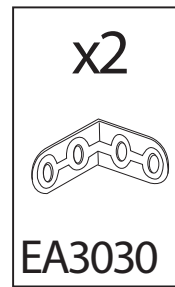
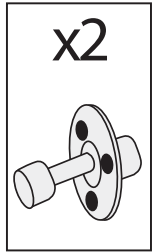
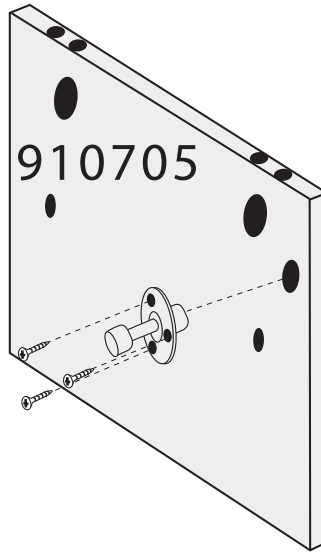
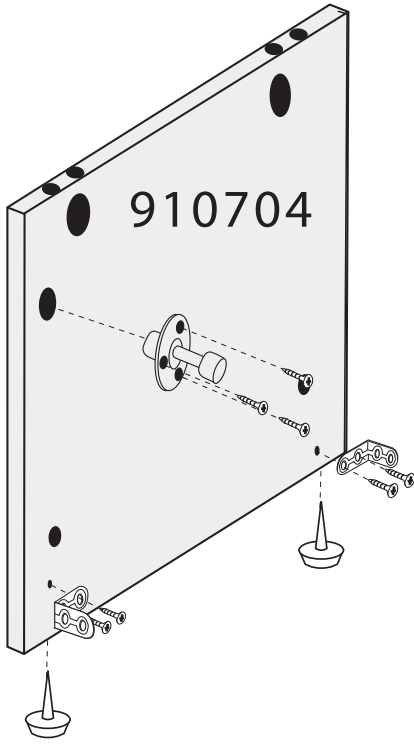

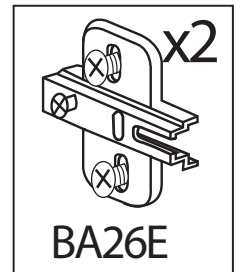
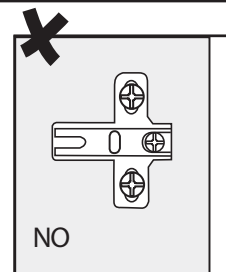
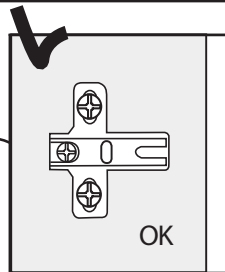

2



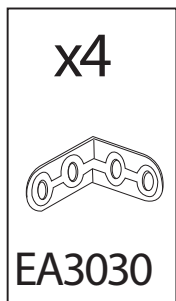
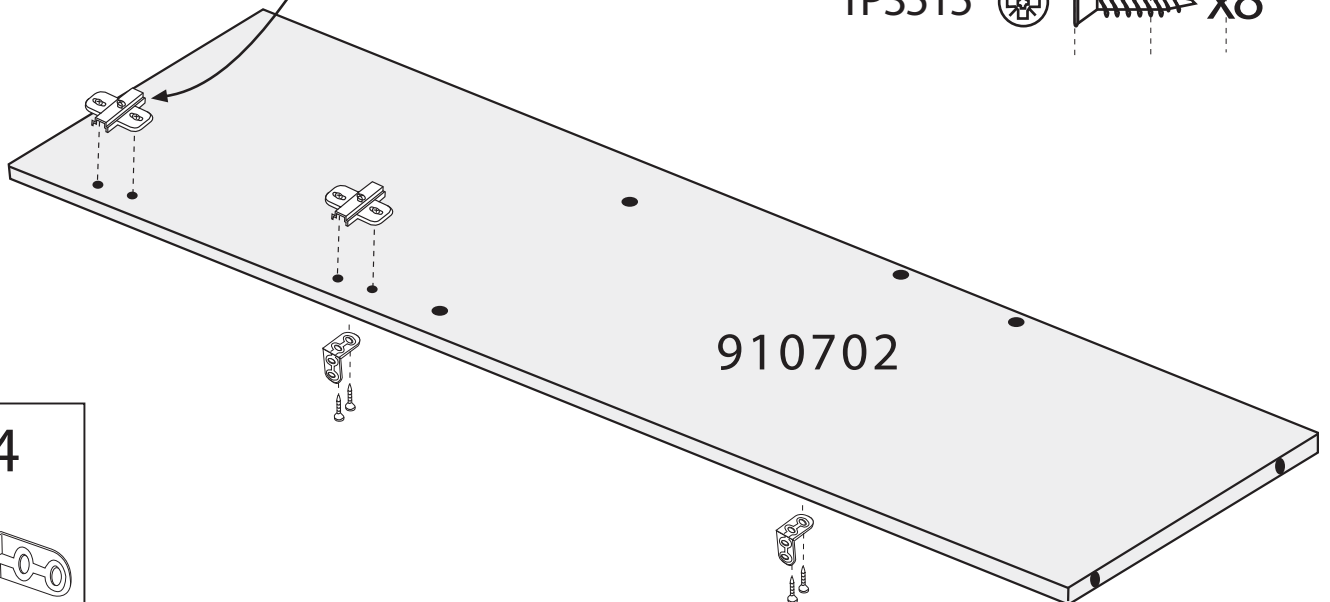

cm 0 1 2

TP3515  x8

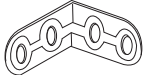

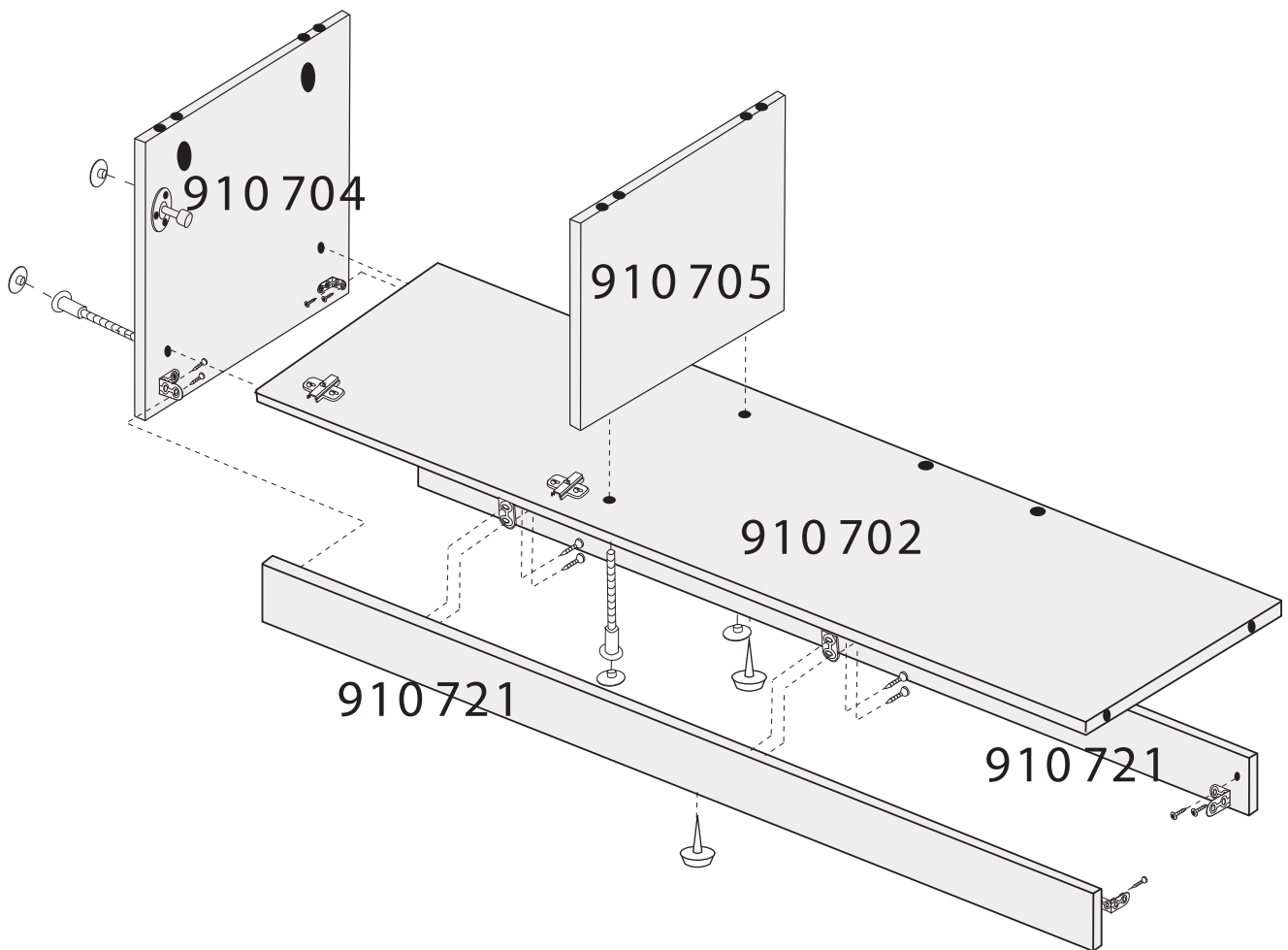
x2  TSR	x4  TA3B	x2  EA3030
--	---	---



cm	0	1	2	3	4	5	
TA550						x4	
TP3515						x16	

4

cm 0 1 2 3 4 5

TA550  x8

TP3515  x4

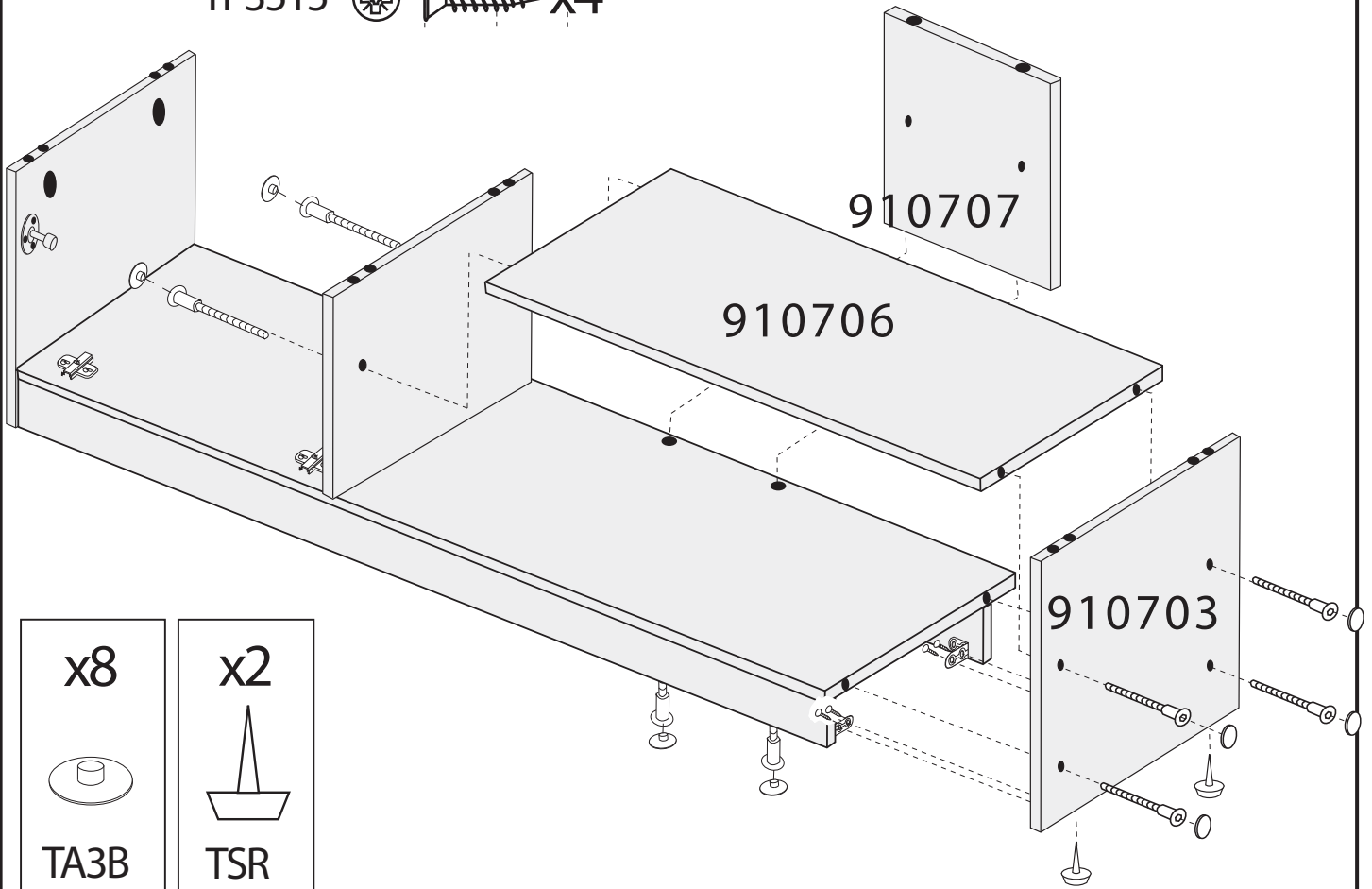

x8

 TA3B

x2

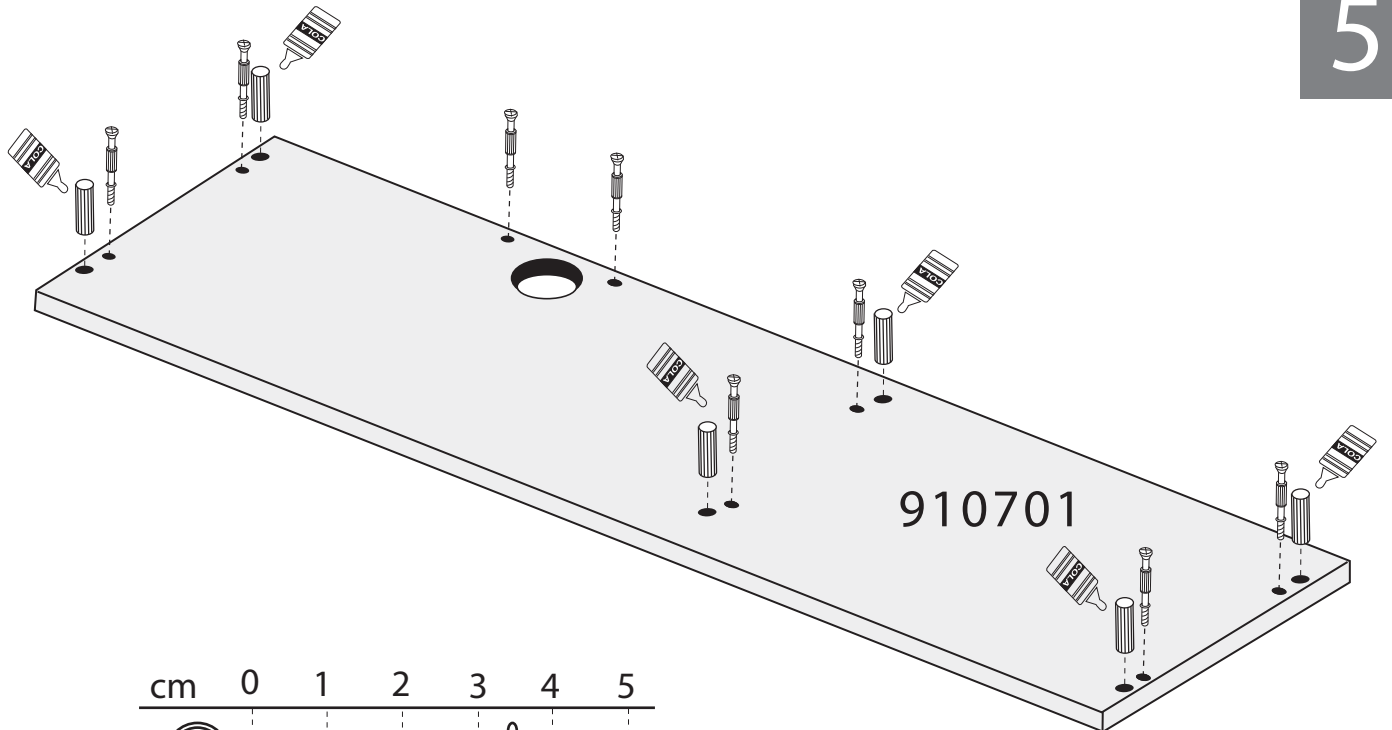
 TSR

5



cm 0 1 2 3 4 5

PE845  x8

CL830  x6

6

910701

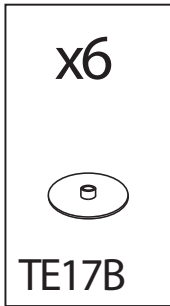
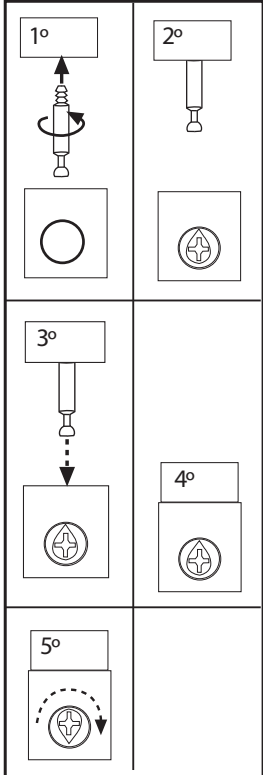
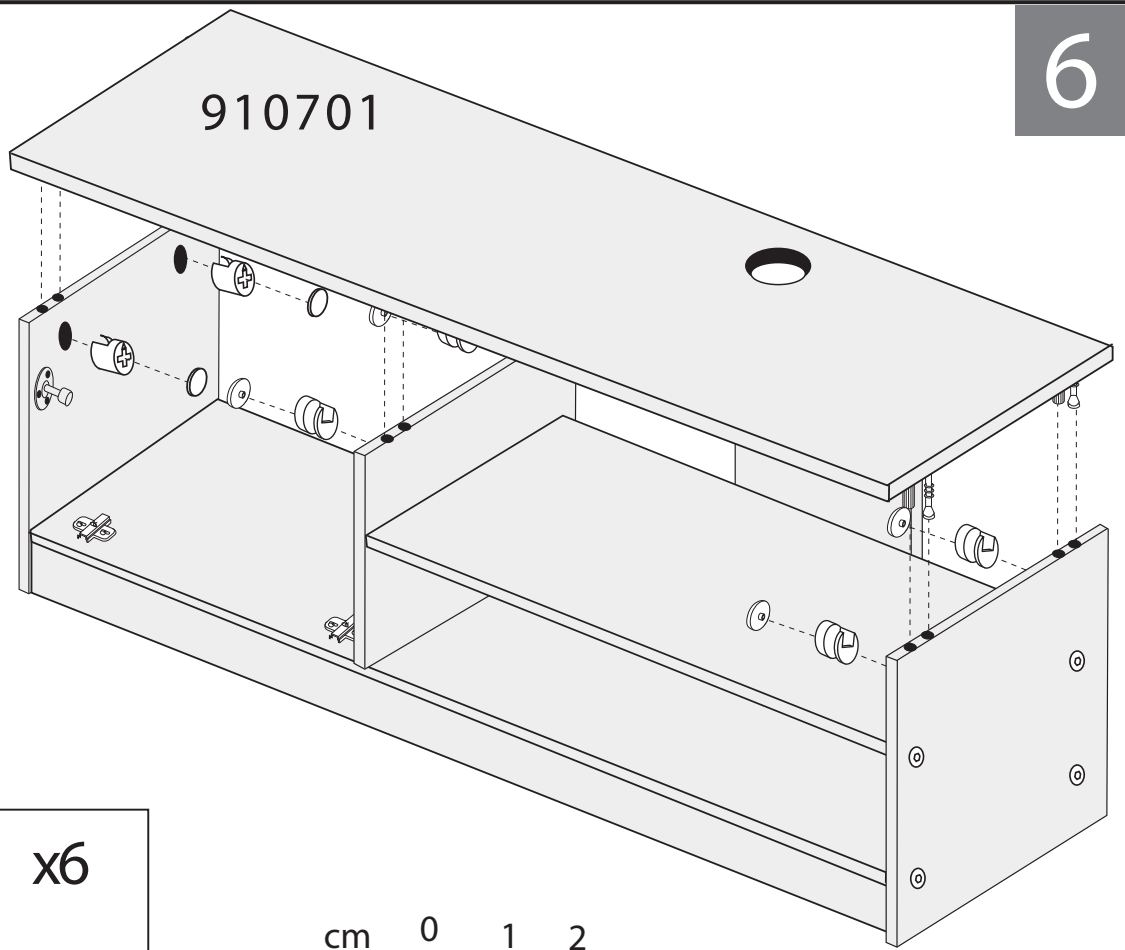

cm 0 1 2

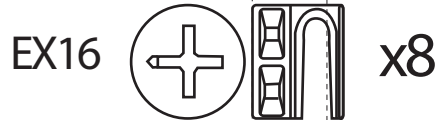

7

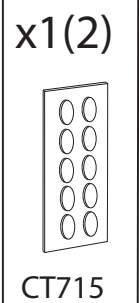
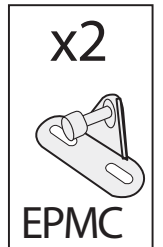
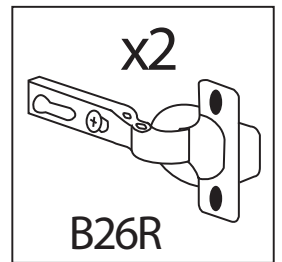
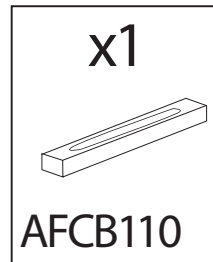
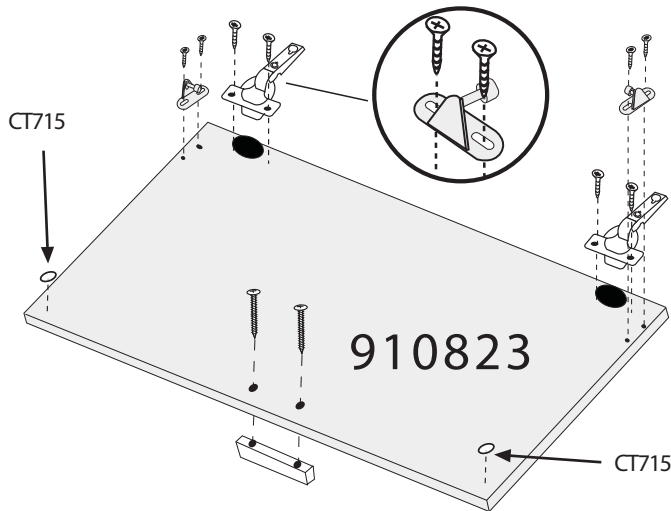

cm 0 1 2 3

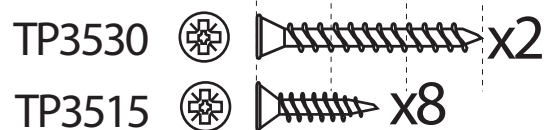

8

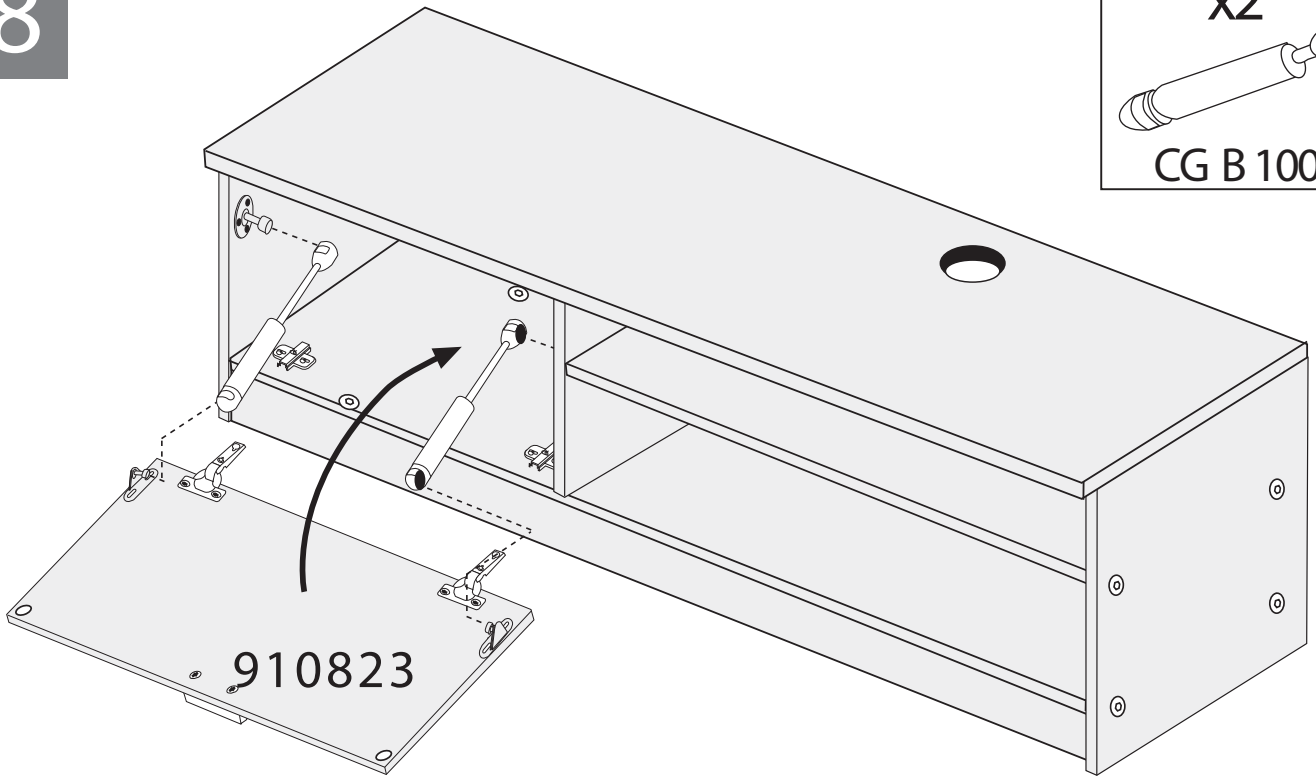

x2
CG B 100

910823

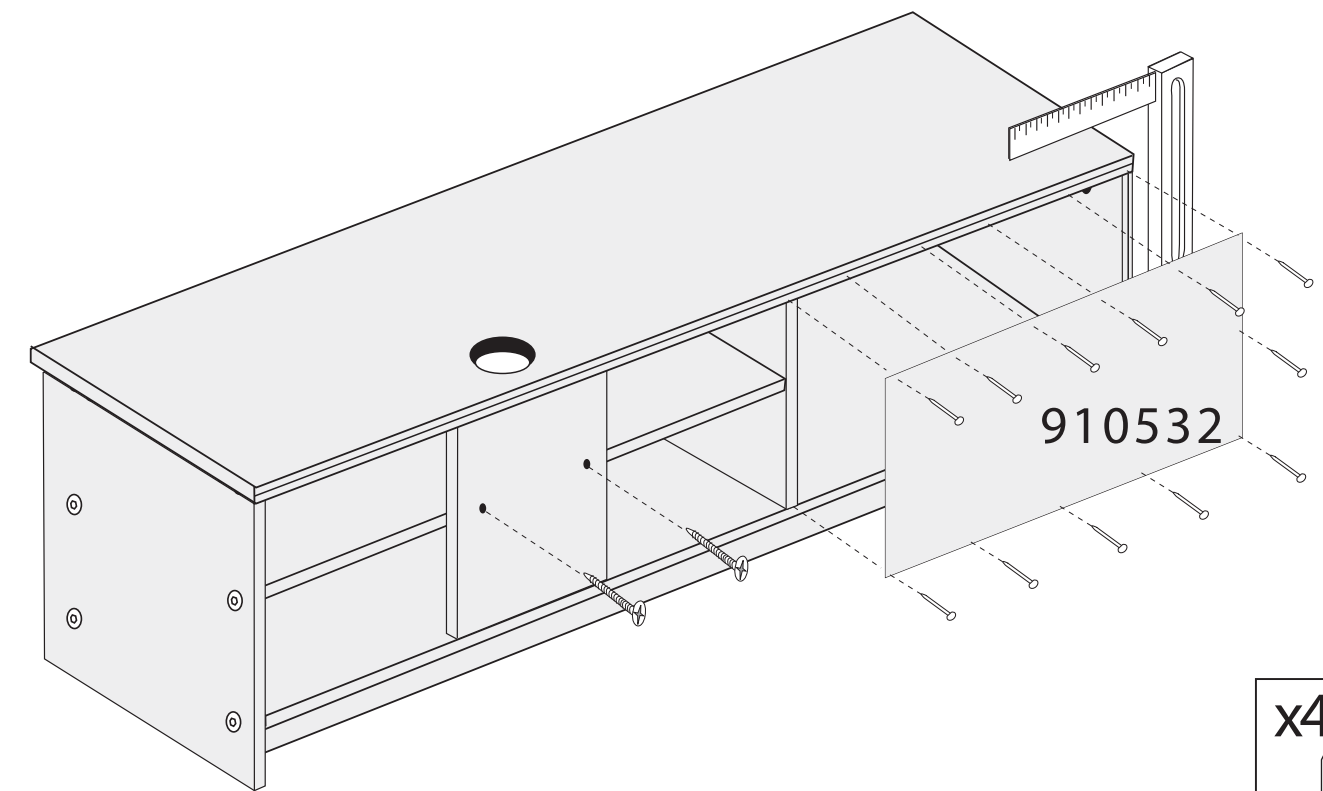

910532

cm 0 1 2 3

TP3530   x2

x40

P1010

9

x4

TSR

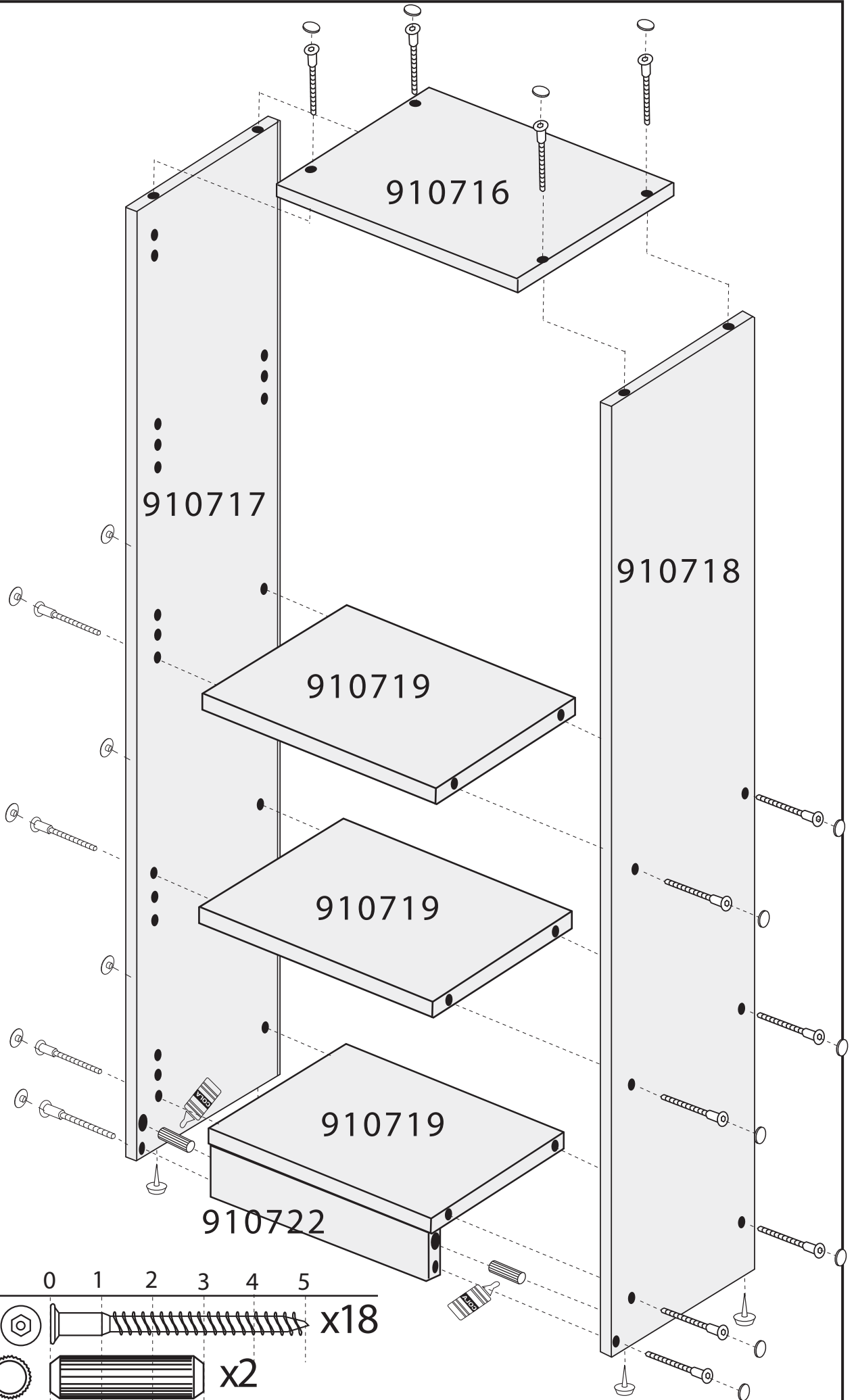
x18

TA3B



cm 0 1 2 3 4 5

TA550  x18

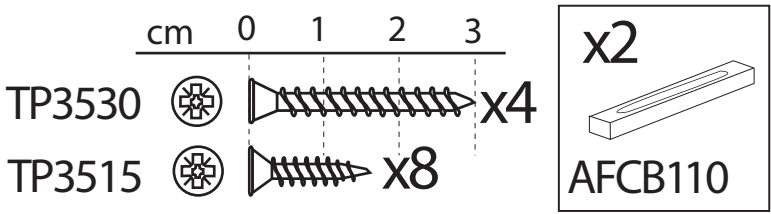
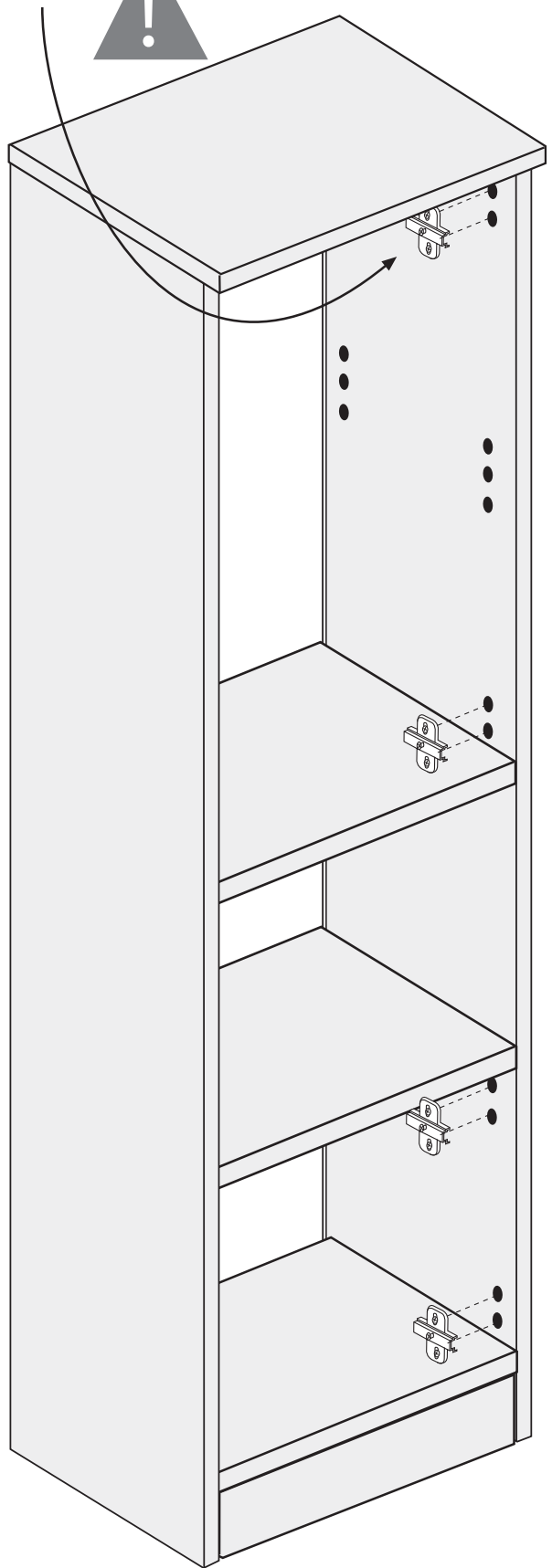
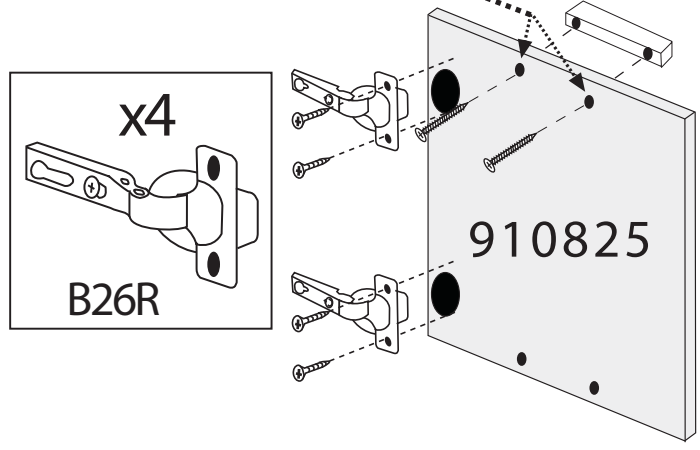
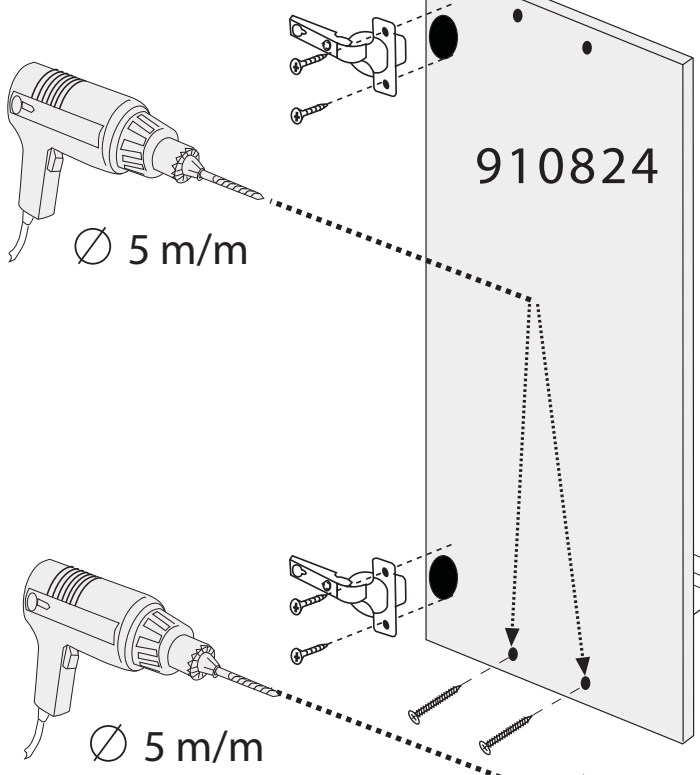
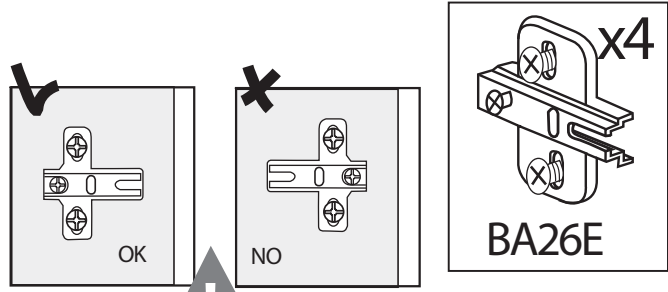
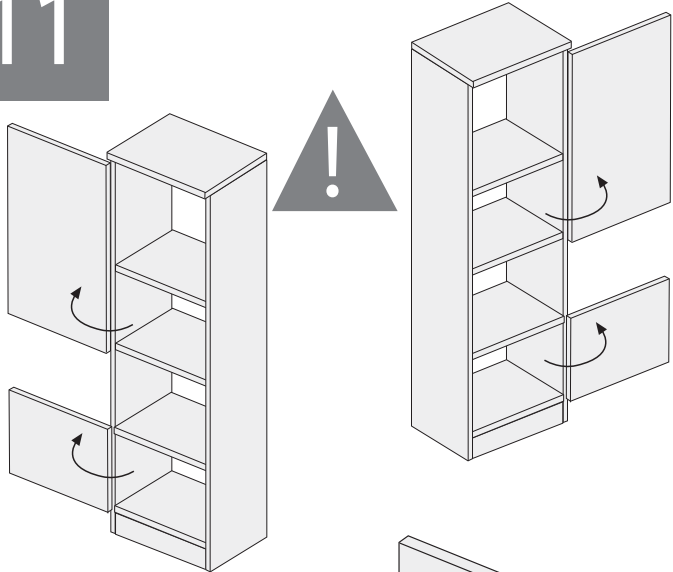
CL830  x2



12

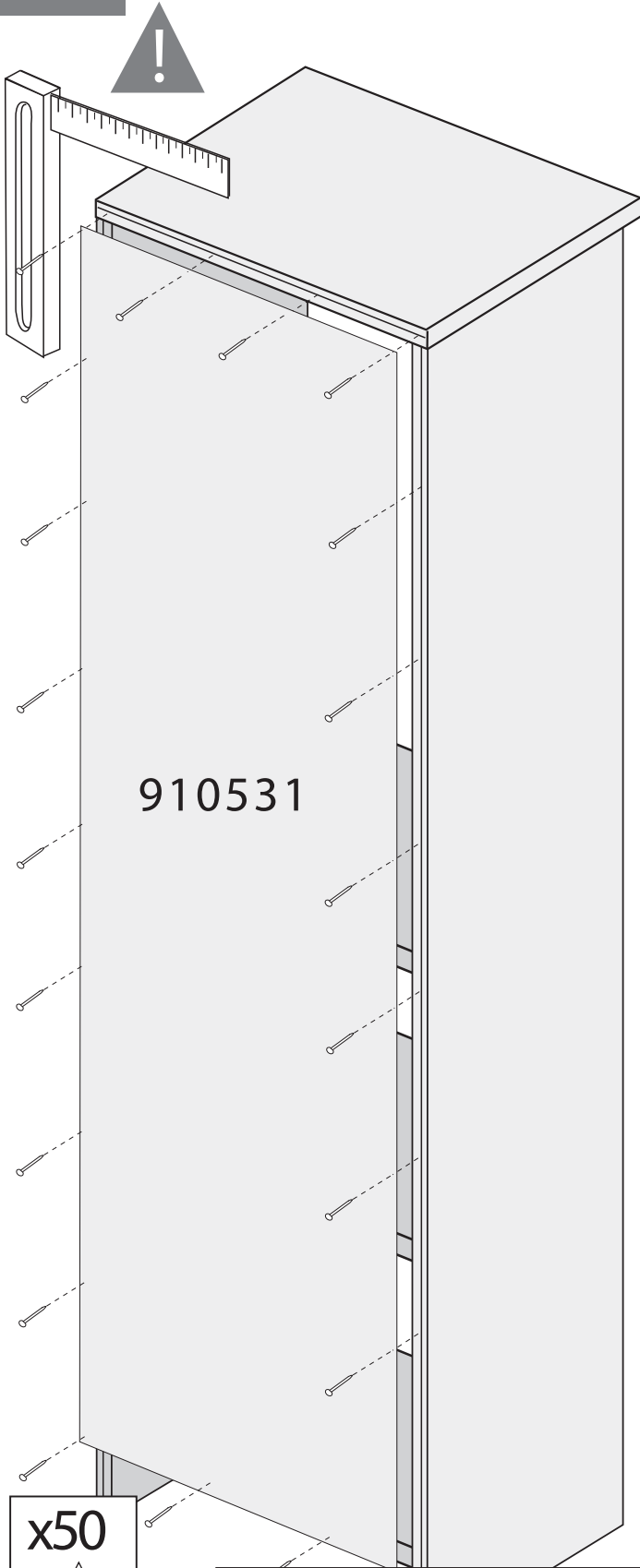

910531

x50



P1010

13

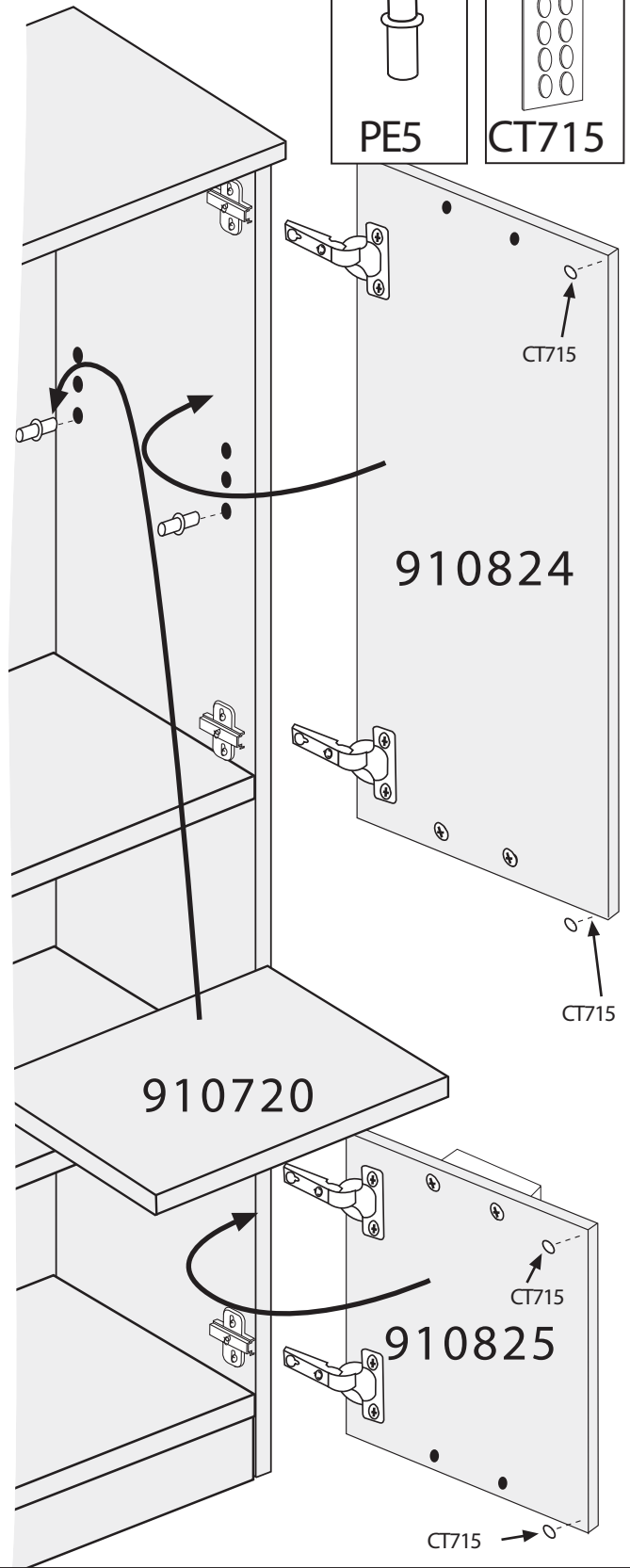

x4



PE5

x1(4)

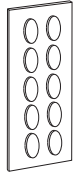

CT715

910824

910720

910825

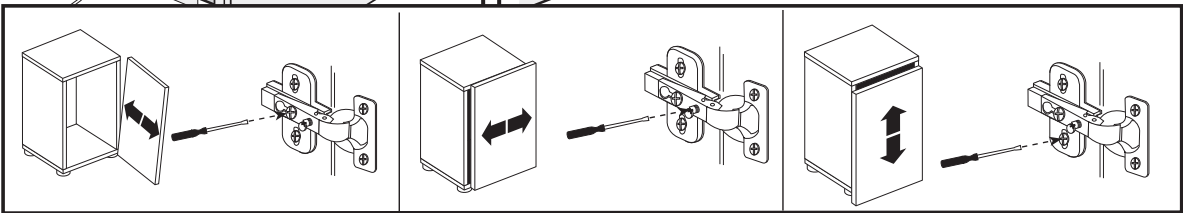

14

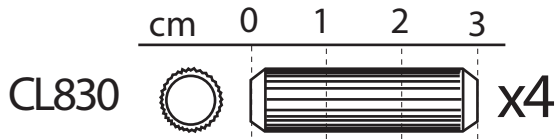
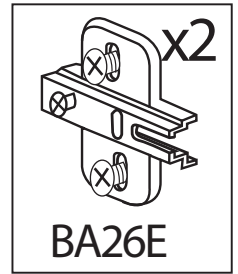
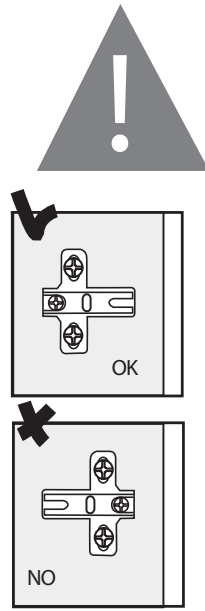
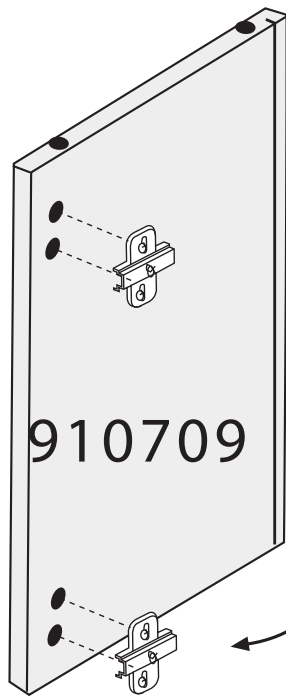

15

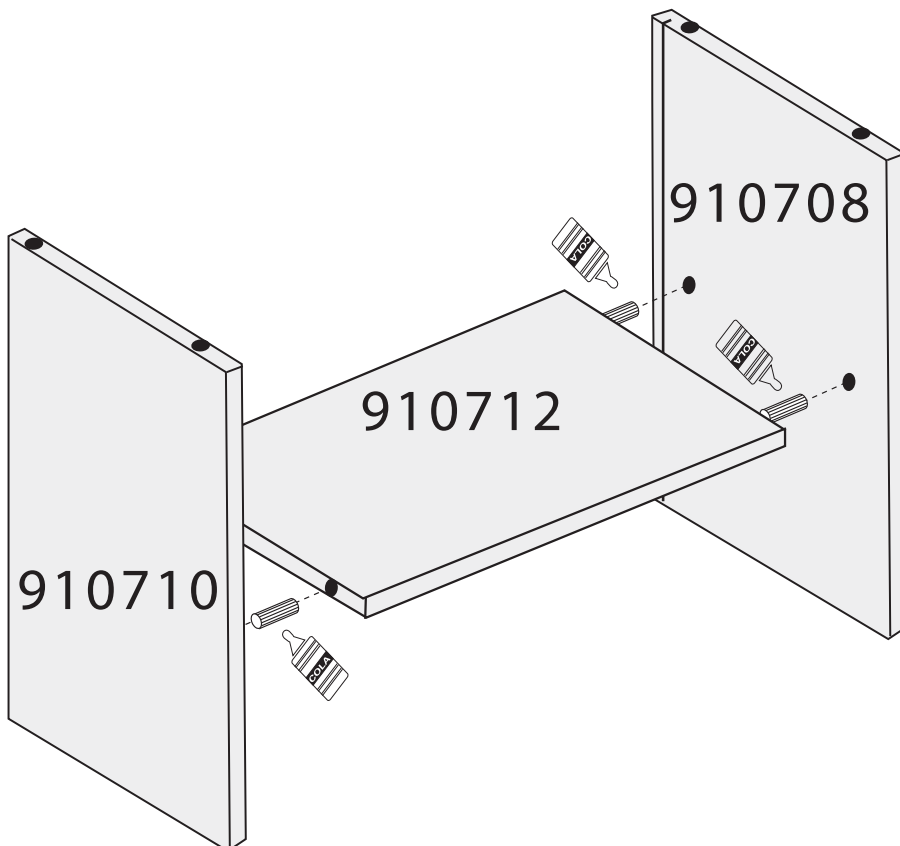

16

x6



TA3B

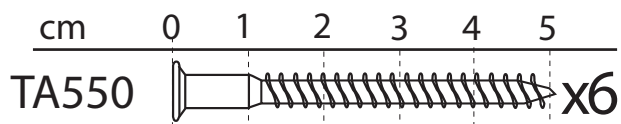
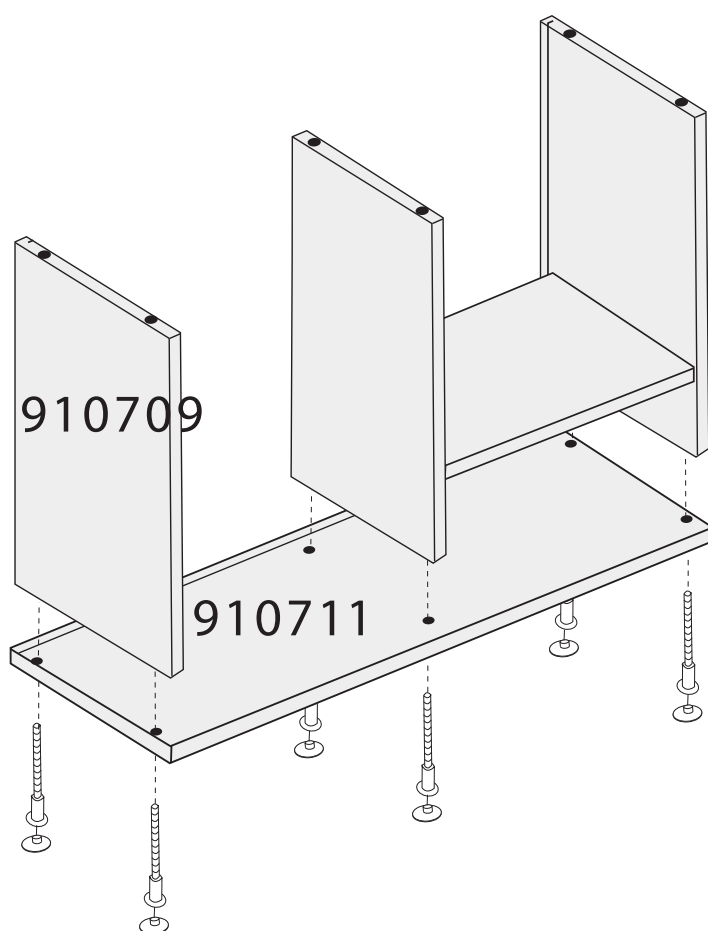

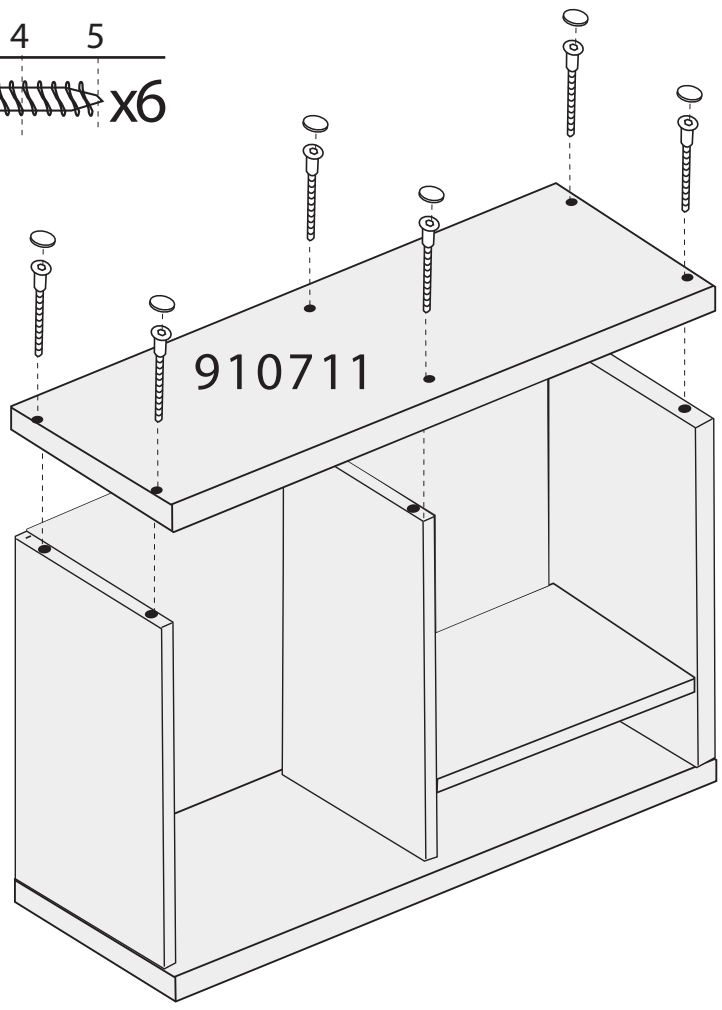

cm 0 1 2 3 4 5
TA550 x6

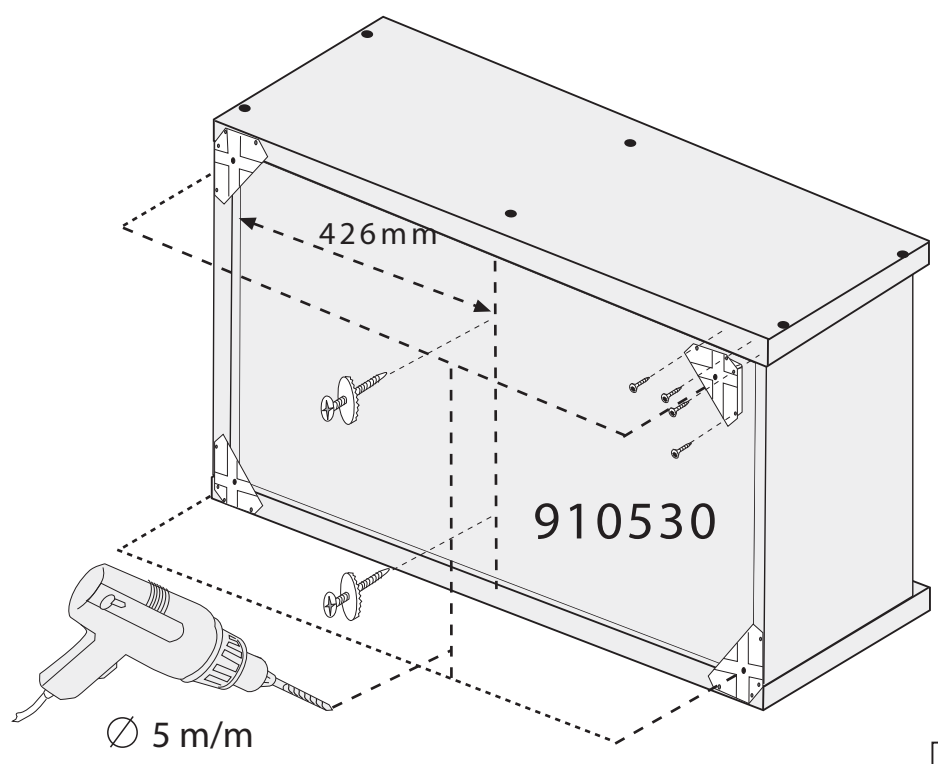

x6

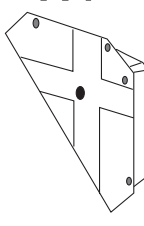
TA3B



x4

ECT10

cm 0 1 2 3
TP3530  x2
TP3515  x16

x2

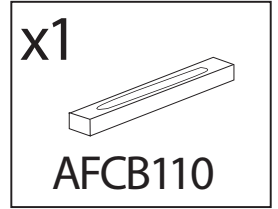
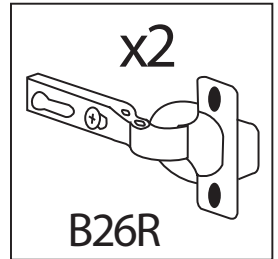
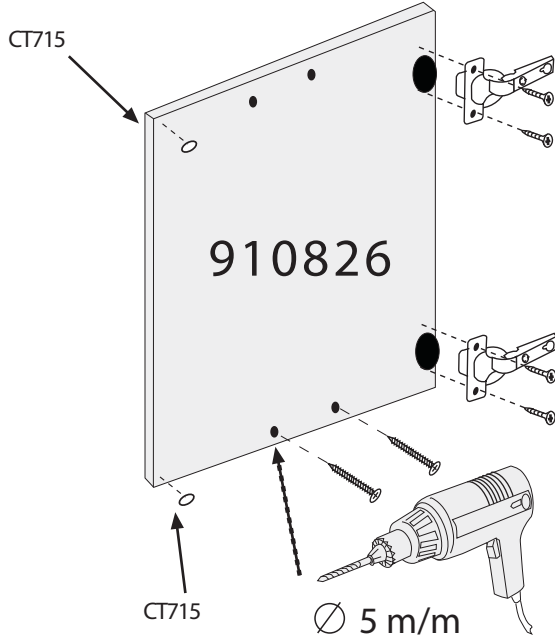
GRTG

19

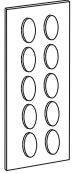

x1(2)



CT715

cm 0 1 2 3

TP3530 x2

TP3515 x4

20

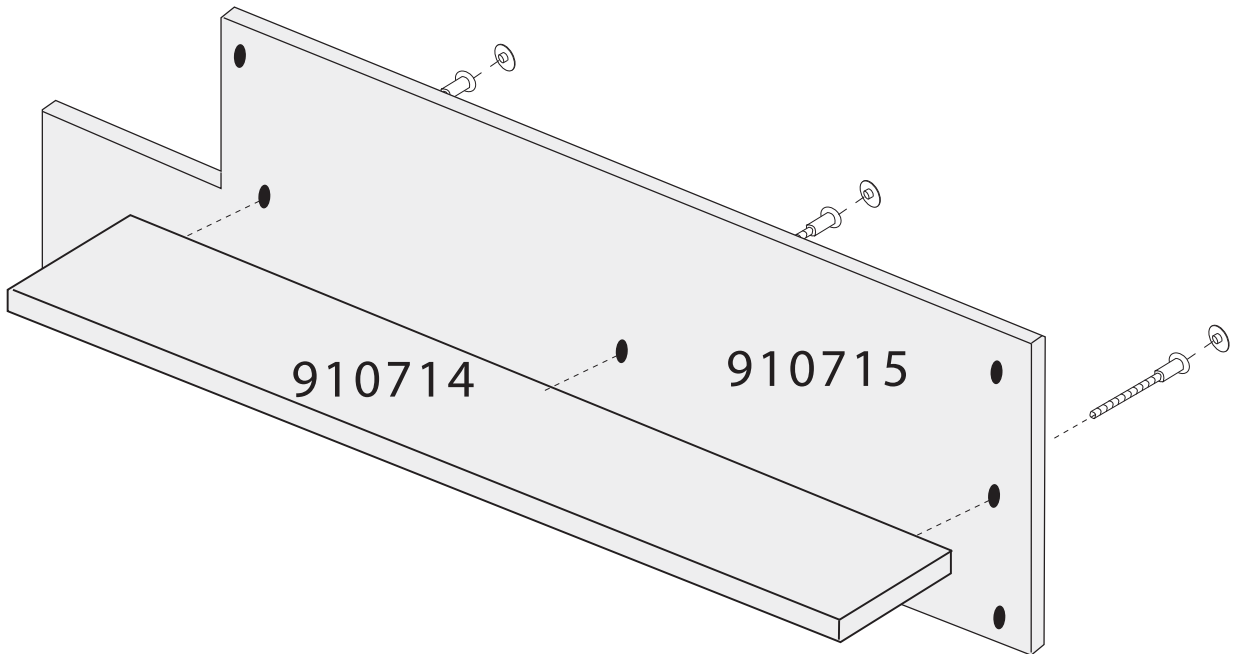

x3



TA3B

cm 0 1 2 3 4 5

TA550 x3

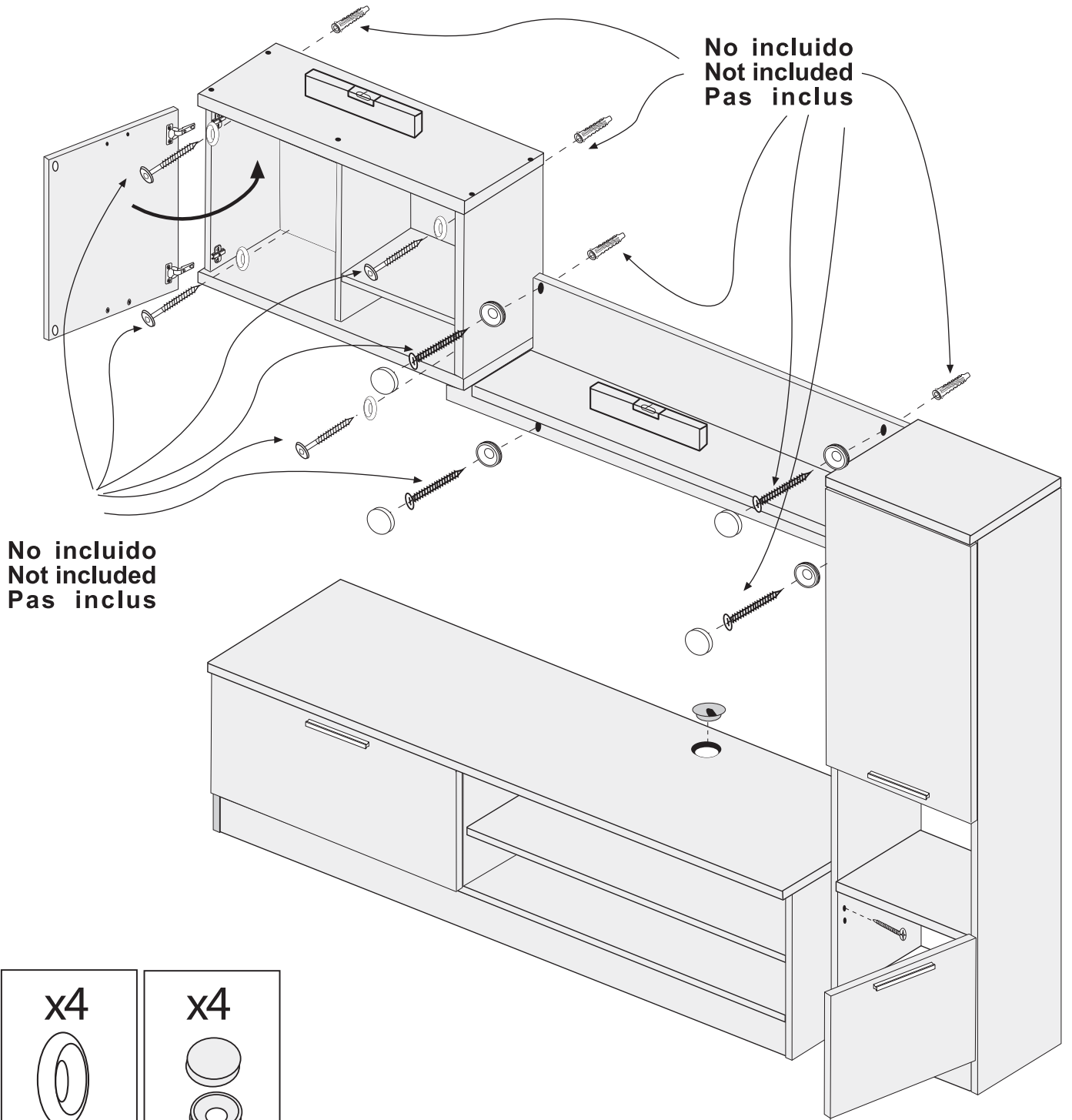
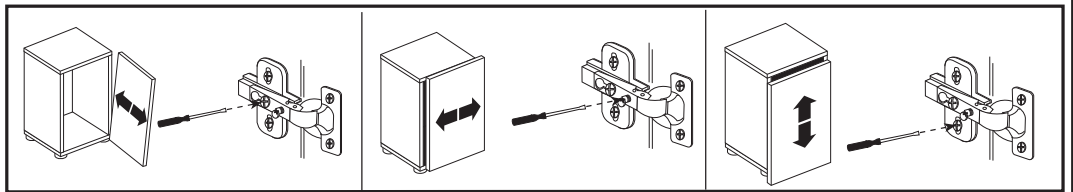

No incluido
Not included
Pas inclus

No incluido
Not included
Pas inclus

x4

TAPALU

x4

TEMB18C

x1

PC60A

cm 0 1 2 3

TP3530 x2

